

TIA-952 Optical/Electrical Converter Operating Instructions



Terahertz Technologies Inc. 169 Clear Road Oriskany NY 13424 (315) 736-3642 FAX (315) 736-4078

E-mail sales@terahertztechnologies.com

Contents

Introduction.....	1
Specifications	2
Unpacking and Inspection.....	3
Battery Replacement.....	3
Controls.....	4
Operating Considerations.....	5
Spectral Response	7
REPAIR INFORMATION	11
LIMITED WARRANTY.....	12

Introduction

The TIA-952 Optical to Electrical Converter is a convenient fiber optic detector/amplifier combination that mounts directly on the input of an oscilloscope, digitizer, or other readout device. With a bandwidth of 800 MHz, it accurately provides an electrical replica of the optical signal presented to it. It is fully capable of driving a 50 ohm cable terminated in its characteristic load.

Two basic models of the unit exist; the TIA-952 S, containing a silicon detector for use in the spectral region between 400 and 1000 nm, and the TIA-525 I which contains an Indium-Gallium-Arsenide detector and is responsive in the 900 to 1700 nm spectral region. Both units may be equipped with either an ST[®] or FC fiber optic connector.

The TIA-952 has a transimpedance of 500 Ω plus a post amplifier with selectable gains of 1 or 5. Thus the overall responsivity ranges from approximately 450 V/W to 2250 V/W at the peak of the detector response curve and when terminated in a 50 ohm load.

The unit is powered by a universal wall mount power supply. The supply accepts mains voltages from 95 to 260 V.A.C., 47-60 Hz. Four mains plugs are provided that are compatible with standards used in North America, Great Britain, Continental Europe and Australia.

®Registered trademark of AT&T

Specifications

Detector Types	Silicon (400-1000 nm), InGaAs (900-1700nm)
Transimpedance.....	500 Ohms
Post Amplifier Gain	1.0, 5.0 selectable
Maximum Linear Input Power.....	2 mW
Max Input Without Damage	15 mW
Bandwidth (-3 dB)	30 KHz to 800 MHz (Gain set to 1) 30 KHz to 300 MHz (Gain set to 5)
Output Impedance	50 Ohms
Output Connector	Male BNC
Fiber Optic Input Connector.....	ST, or FC
Input Numerical Aperture	0.29
Output Offset Voltage	< +/- 0.01 V at max gain
Maximum Output Voltage	4 V pk-pk, gain of 5, 2 V pk-pk, gain of 1 into 50 ohm load
Noise Level	9.5 pW/Hz ^{1/2} at peak responsivity
Power Required.....	95 - 260 V.A.C., 47 - 60 Hz, < 6 VA
Dimensions	1.2" W, 2.5"L, 1.25"H, (30.5 mm, 63 mm, 30 mm)
Operating Temperature	0 - 40 C
Limited Warranty	2 Years from date of receipt
Weight	5 oz, 150 g

Powering the Unit

The TIA-952 is equipped with a universal 12 volt regulated power supply that operates from 95 to 260 VAC, 47-60 Hz. Each unit is supplied with four interchangeable power plugs that equip the unit for use in North America, Europe, Great Britain or Australia. Simply snap on the appropriate mains connector and plug the 2.1 mm coaxial plug into the receptacle located just under the optical input connector. Then plug the power supply into a power outlet. Sliding the unit's power switch to the On position should result in the green power-on indicator LED turning on.

Unpacking and Inspection

Prior to shipment this instrument was inspected and found to be free of mechanical and electrical defects. Upon acceptance by the carrier he assumes responsibility for its safe arrival. After unpacking, examine the unit for any evidence of shipping damage. Should you receive this instrument in a damaged condition, apparent or concealed, it must be noted on the freight bill or express receipt and signed by the carrier's agent. Failure to do so could result in the carrier refusing to honor the claim. Upon filing a claim TTI should be notified.

Controls

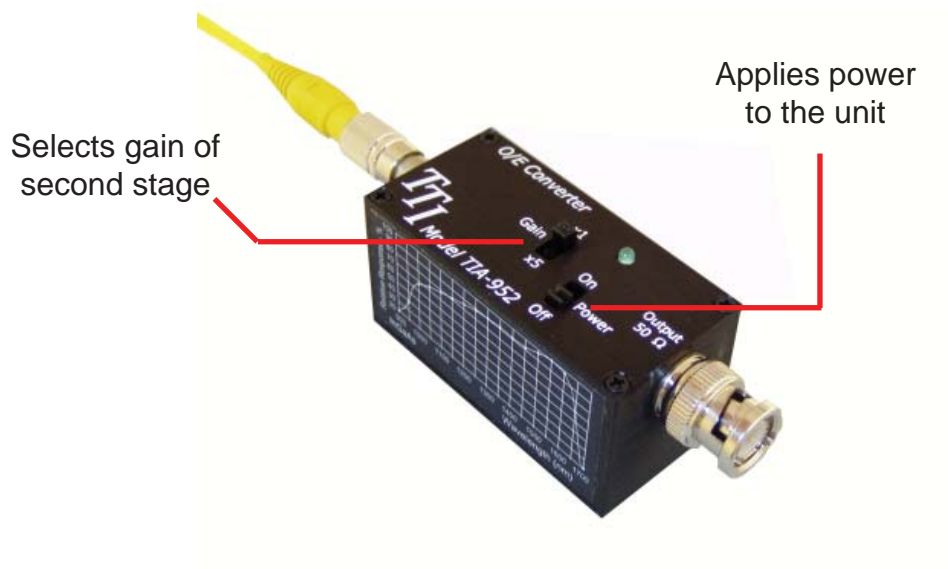

Operating Considerations

The TIA-952 is comprised of a fiber coupled detector and two amplifier stages. The first amplifier is a transimpedance stage which converts the detector output current to a voltage by passing it through a resistor of 500 ohms. Additional amplification is optionally provided by the second stage which also serves to provide 50 ohm drive capability. The amplifiers are AC coupled.

The overall bandwidth of the unit is determined by the second stage gain setting. The bandwidths in excess of 800 MHz when the second stage is set for a gain of 1 and 300 MHz when it is set to a gain of 5. The overall responsivity of the unit in terms of Volts/Watt is the current responsivity of the detector multiplied by the transimpedance and further multiplied by the second stage gain. For example, the sensitivity of the unit at a wavelength of 1550 nm would be $0.9 \text{ A/W} \times 500 \text{ V/A} \times 5 = 2,250 \text{ V/W}$.

When using the TIA-952 mounted on an oscilloscope, the scope should have its input impedance set to 50 ohms. If driving a coaxial cable, the cable should have a 50 ohm characteristic impedance and be terminated with a 50 ohm load.

Spectral Response

The approximate relative response curves of the detectors employed is as shown below. Note that these are representative curves and do not necessarily correspond to the exact response of the particular detector in use.

The approximate power at the detector surface is given by:

$$\text{Input power in watts (InGaAs)} = \frac{\text{Peak output voltage (50 ohm load)}}{0.9 \text{ A/W} \times T_R \times \% \text{ Relative response from graph}/100}$$

$$\text{Input power in watts (Si)} = \frac{\text{Peak output voltage (50 ohm load)}}{0.55 \text{ A/W} \times T_R \times \% \text{ Relative response from graph}/100}$$

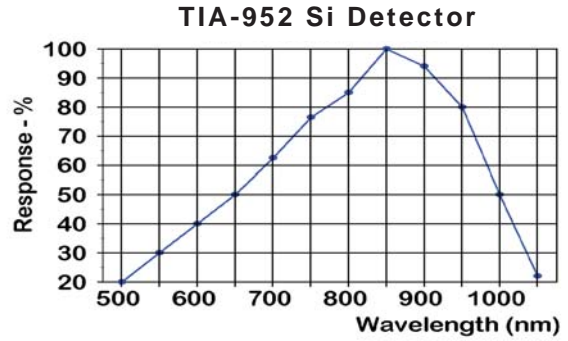
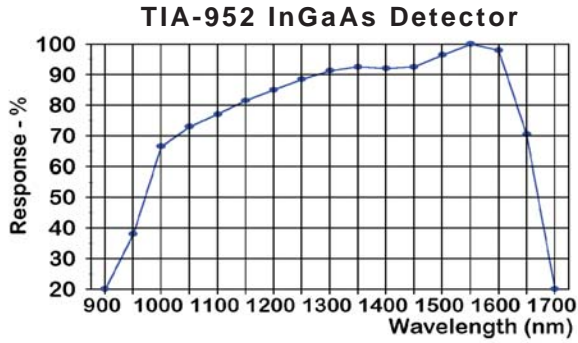

Warranty And Repair Information

REPAIR INFORMATION

Products manufactured by Terahertz Technologies Inc. are designed and fabricated to provide reliable performance. However, in the event that service is required, both telephone technical assistance and factory repair services are available. Call (315) 736-3642 for information.

For IN-WARRANTY REPAIRS, call us to obtain a Returned Material Authorization number, (RMA Number). All products are to be returned to TTI with freight charges pre-paid. Those products sent under warranty will be returned to our customers pre-paid. We cannot be responsible for returned products that do not reference the TTI RMA number.

For OUT-OF-WARRANTY repairs, services are billable for both time and materials.

Calibration - This is a qualitative measurement device. No calibration is required or necessary.

LIMITED WARRANTY

TERAHERTZ TECHNOLOGIES INC. (TTI) WARRANTS THAT TO THE FIRST PURCHASER, FOR A PERIOD OF TWO YEARS FROM THE DATE OF RECEIPT, THAT THIS PRODUCT (THE PRODUCT) WILL BE FREE FROM DEFECTS IN MATERIALS AND MANUFACTURING. THE FOREGOING WARRANTY IS THE ONLY WARRANTY, EXPRESS OR IMPLIED, GIVEN BY TTI, I.E., THERE IS NO WARRANTY OF FITNESS FOR A PARTICULAR PURPOSE. TTI HEREBY DISCLAIMS ANY EXPRESS OR IMPLIED WARRANTY OTHER THAN THE WARRANTY IN THE FIRST SENTENCE TO THE FULLEST EXTENT PERMITTED BY LAW.

THE SOLE AND EXCLUSIVE REMEDY UNDER THIS WARRANTY IS REPAIR OR REPLACEMENT AT TTI'S OPTION OF ANY PRODUCT THAT PROVES TO BE DEFECTIVE IN MATERIALS OR MANUFACTURING WITHIN TWO YEARS OF RECEIPT OF THE PRODUCT. NOTE: THIS WARRANTY DOES NOT APPLY TO ANY PRODUCT WHICH HAS BEEN SUBJECT TO MISHANDLING, MISUSE, OR SERVICE BY UNAUTHORIZED PERSONNEL OR TO ANY PRODUCT WHICH HAS BEEN DAMAGED, MODIFIED, ALTERED OR TAMPERED WITH. TO THE FULLEST EXTENT OF THE LAW, TTI DISCLAIMS ALL LIABILITY FOR ANY OTHER DIRECT, INCIDENTAL OR CONSEQUENTIAL DAMAGES ALLEGED TO BE CAUSED BY A DEFECTIVE PRODUCT, I.E., TTI WILL NOT BE RESPONSIBLE FOR ANY PERSONAL INJURY, PROPERTY DAMAGE OTHER THAN THE COST OF REPLACING THE PRODUCT OR ANY OTHER MONETARY DAMAGE SUCH AS LOST WAGES OR PROFITS CAUSED BY ANY USE, ATTEMPTED USE OR INABILITY TO USE THE PRODUCT. NOTE: BY USING THE PRODUCT, YOU AGREE THAT REPAIR OR REPLACEMENT AT TTI'S OPTION WILL FULLY SATISFY TTI'S WARRANTY OBLIGATION TO YOU, WHETHER IN CONTRACT, TORT, NEGLIGENCE, STRICT LIABILITY OR OTHER APPLICABLE LAW.