

TIA-527 Balanced Optical/Electrical Converter Operating Instructions



Terahertz Technologies Inc. 169 Clear Road Oriskany NY 13424 (315) 736-3642 FAX (315) 736-4078

E-mail sales@terahertztechnologies.com

Contents

Introduction	1
Specifications	2
Unpacking and Inspection	3
Battery Replacement	3
Controls	4
Operating Considerations	5
Spectral Response	7
REPAIR INFORMATION	11
LIMITED WARRANTY	12

Introduction

The TIA-527 Balanced Optical to Electrical Converter is a convenient battery-operated detector/amplifier combination that mounts directly on the input of an oscilloscope, digitizer, or other readout device. With a band width of DC to 125 MHz, it accurately provides an electrical replica of the difference of two optical signals presented to its two matched InGaAs detectors. It is fully capable of driving a 50 ohm cable terminated in its characteristic load.

The TIA-527 has selectable transimpedances of 1.4 K Ω and 14 K Ω plus a post amplifier with selectable gains of 1 or 10. Thus the overall responsivity ranges from approximately 1,000 V/W to 100,000 V/W at the peak of the detector response curve. Interstage coupling may be switched from DC to AC to avoid saturation of the second stage in those cases where the signal of interest is combined with a relatively large DC optical component

Each unit is powered by a self-contained 9 V lithium battery or a universal wall mount power supply. Battery operation eliminates ground loops and the undesirable effects of conducted radiation that may be present on local power lines.

®Registered trademark of AT&T

Specifications

Detector Types	InGaAs (900-1700nm)
Transimpedance.....	1.4K, 14K selectable
Post Amplifier Gain	1.0, 10.0 selectable
Maximum Linear Input Power	1.2 mW
Max Input Without Damage	10 mW
Bandwidth (-3 dB)	DC to 125 MHz at 1.4 K Transimpedance DC to 35 MHz at 14 K Transimpedance
Output Impedance	50 Ohms
Output Connector	Male BNC
Fiber Optic Input Connector	ST, (FC or unconnectorized on special request)
Input Numerical Aperture	0.29
Interstage Coupling	DC or AC (5 Hz low frequency cut off)
Output Offset Voltage	< +/- 0.1 V at max gain
Maximum Output Voltage	4 V pk-pk, no load, 2 V pk-pk, 50 ohm load (AC coupling)
Noise Level	3.6 pW/Hz ^{1/2}
Power Required.....	9 V Lithium Battery powers the unit for approximately 30 hrs (no load)
Dimensions	1.2" W, 2.5"L, 1.5"H, (30.5 mm, 63 mm, 38 mm)
Operating Temperature	0 - 40 C
Limited Warranty	2 Years from date of receipt
Weight	5 oz, 150 g

Unpacking and Inspection

Prior to shipment this instrument was inspected and found to be free of mechanical and electrical defects. Upon acceptance by the carrier he assumes responsibility for its safe arrival. After unpacking, examine the unit for any evidence of shipping damage. Should you receive this instrument in a damaged condition, apparent or concealed, it must be noted on the freight bill or express receipt and signed by the carrier's agent. Failure to do so could result in the carrier refusing to honor the claim. Upon filing a claim TTI should be notified.

Battery Replacement

Each unit comes equipped with a 9 V Lithium battery that provides power to the unit for approximately 30 hours of operation. It is recommended that the battery be replaced whenever the output signal becomes clipped at 1 volt or less. When replacing the battery, a Lithium unit should be used. Conventional 9 V alkaline batteries may be used if so desired but the useful life will only be about 25 % (8 hours) of that of the much higher capacity Lithium types. TTI can supply these batteries if desired. Replacement of the battery may be accomplished by removing the four 2-56 Philips flat head screws that retain the bottom cover of the TIA-527. **DO NOT** attempt to remove the top cover. Take care to replace all screws tightly. This will provide optimum shielding of the unit from ambient radio frequency noise or interference.

The TIA-527 is also supplied with a universal power supply that operates from 90 to 240 VAC, 50-60 Hz. Each unit is equipped with four interchangeable power plugs that equip the unit for use in North America, Europe, the UK or Australia. Plugging the power supply into the unit disconnects the internal battery.

Controls

Applies power to the unit

Selects gain of second stage

Optical Input Connectors

Selects interstage coupling

Selects transimpedance of first stage

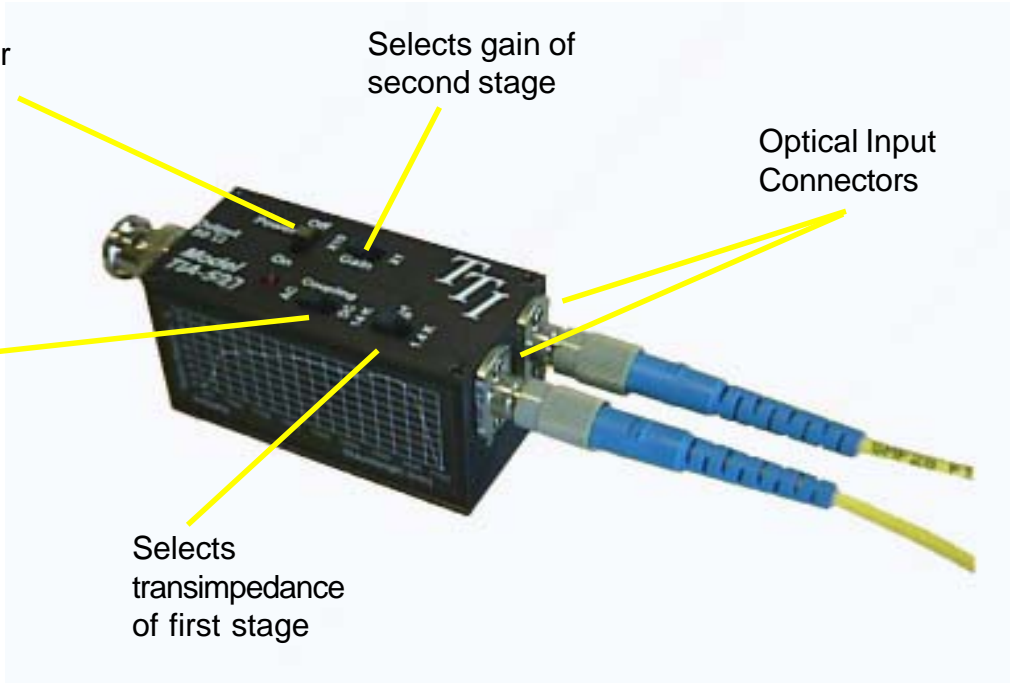

Operating Considerations

The TIA-527 is comprised of two fiber coupled detectors and two amplifier stages. The first amplifier is a transimpedance stage which converts the net detector output current to a voltage by passing it through a resistor of 1 400 or 14 000 ohms. Additional amplification is optionally provided by the second stage which also serves to provide 50 ohm drive capability. Either AC or DC coupling between the stages may be selected.

The overall bandwidth of the unit is determined by the first stage transimpedance. It is in excess of 125 MHz when the T R switch is in the 1.4 K position and is 35 MHz in the 14 K position. The overall responsivity of the unit in terms of Volts/Watt is the current responsivity of the detector multiplied by the transimpedance and further multiplied by the second stage gain. For example, the sensitivity of the unit at a wavelength of 1300 nm would be $0.7 \text{ A/W} \times 1400 \text{ V/A} \times 10 = 10,000 \text{ V/W}$. It is evident that the same responsivity may be obtained by using a transimpedance of 14 K and a second stage gain of one. However, the first setting will provide a bandwidth of 125 MHz while the second will provide a bandwidth of 35 Mhz. Since the overall peak-to-peak output noise increases with bandwidth, it is desirable to use the higher transimpedance setting assuming that the signal of interest does not exceed 35 MHz.

The selection of AC interstage coupling is useful when the user needs to examine a small signal in the presence of a large DC optical component, (e.g. baseband fiber optic video). This will preclude the last stage from saturating on the DC component. Otherwise, DC coupling should be employed.

When using the TIA-527 mounted on an oscilloscope, the scope may have its input set to either 50 or 1 Meg ohm input impedance. If driving a coaxial cable, the cable should have a 50 ohm characteristic impedance and be terminated with a 50 ohm load. Note that the signal amplitude will be reduced by a factor of two.

The following table summarizes the operation of the unit under various operating conditions.

Setting Signal	T_R	AC/DC Coupling	2nd Stage
Small signal on large DC components	1.4 K	AC	X 1, X 10 As Needed
High frequency signal, > 35 MHz	1.4 K	DC	X 1, X 10 As Needed
Low level signal, < 35 MHz	14 K	DC	X 1, X 10 As Needed
Low level, high frequency signal	1.4 K	DC	X 10

Spectral Response

The approximate relative response curves of the detectors employed is as shown below. Note that these are representative curves and do not necessarily correspond to the exact response of the particular detector in use.

The approximate power at the detector surface is given by:

$$\text{Input power in watts (InGaAs)} = \frac{\text{Peak output voltage (no load)}}{0.8 \text{ A/W} \times T_R \times \% \text{ Relative response from graph}/100}$$

$$\text{Input power in watts (Si)} = \frac{\text{Peak output voltage (no load)}}{0.55 \text{ A/W} \times T_R \times \% \text{ Relative response from graph}/100}$$

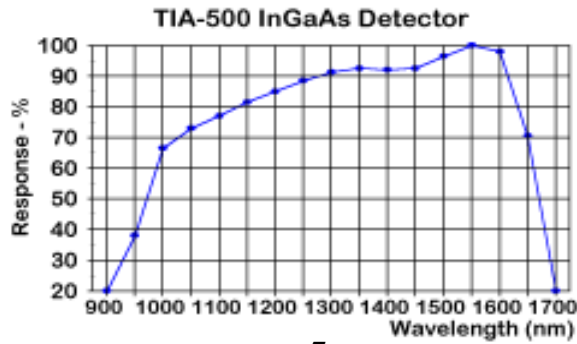

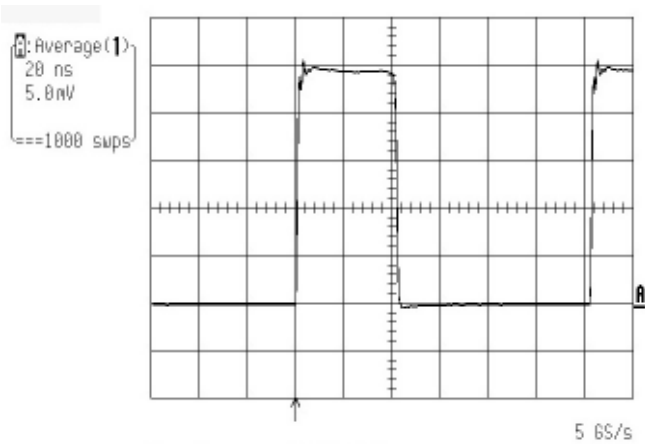

Freq(1) 8.19347 MHz
 sdev(1) 11.294 nV
 rise(1) 0.91 ns
 fall(1) 1.41 ns
 Freq(1) 8.19347 MHz

20 ns RIS
 1 5 nV 50Ω

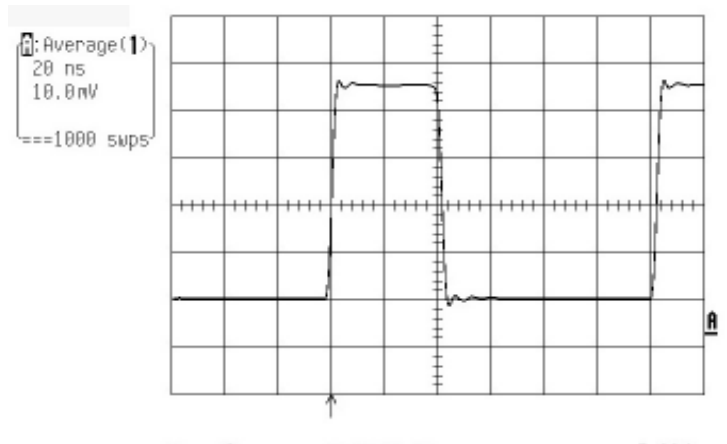

Freq(1) 8.18723 MHz
 sdev(1) 20.34 nV
 rise(1) 2.52 ns
 fall(1) 2.85 ns
 Freq(1) 8.18723 MHz

20 ns RIS
 1 10 nV 50Ω

Optical Input

Output; $T_R = 1.4$ K, Gain = 1

Typical Waveforms

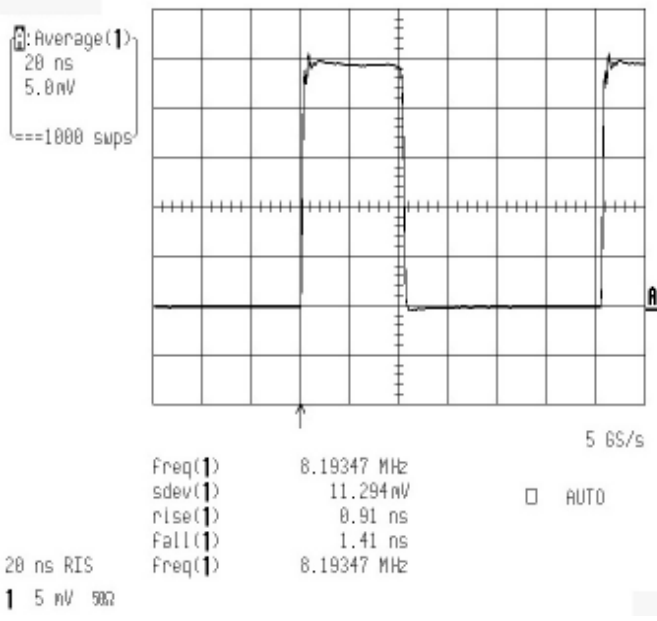

Optical Input

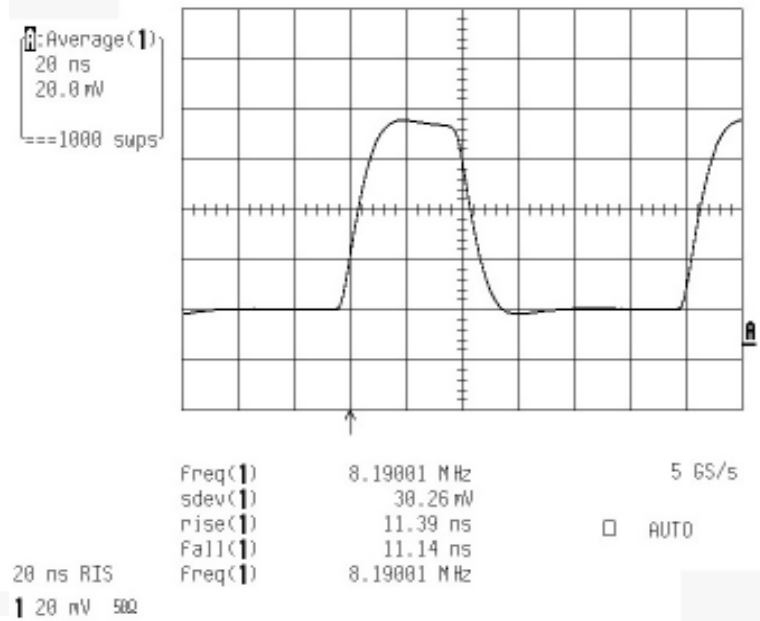

Output; $T_R = 14$ K, Gain = 1

Typical Waveforms

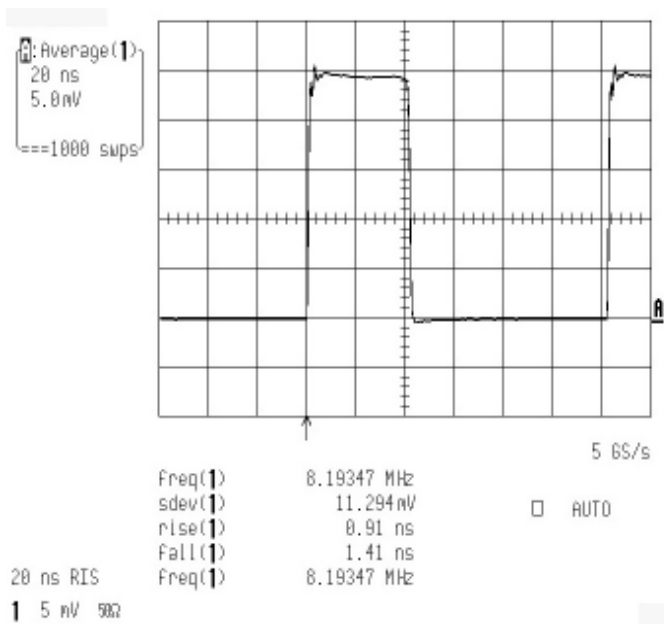

Optical Input

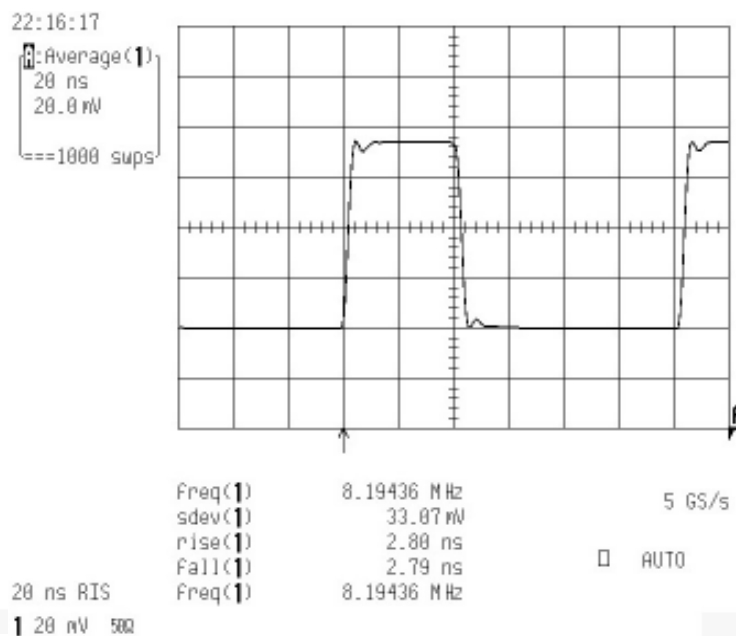

Output; $T_R = 1.4$ K, Gain = 10

Typical Waveforms

Warranty And Repair Information

REPAIR INFORMATION

Products manufactured by Terahertz Technologies Inc. are designed and fabricated to provide reliable performance. However, in the event that service is required, both telephone technical assistance and factory repair services are available. Call (315) 736-3642 for information.

For IN-WARRANTY REPAIRS, call us to obtain a Returned Material Authorization number, (RMA Number). All products are to be returned to TTI with freight charges pre-paid. Those products sent under warranty will be returned to our customers pre-paid. We cannot be responsible for returned products that do not reference the TTI RMA number.

For OUT-OF-WARRANTY repairs, services are billable for both time and materials.

Calibration - This is a qualitative measurement device. No calibration is required or necessary.

LIMITED WARRANTY

TERAHERTZ TECHNOLOGIES INC. (TTI) WARRANTS THAT TO THE FIRST PURCHASER, FOR A PERIOD OF TWO YEARS FROM THE DATE OF RECEIPT, THAT THIS PRODUCT (THE PRODUCT) WILL BE FREE FROM DEFECTS IN MATERIALS AND MANUFACTURING. THE FOREGOING WARRANTY IS THE ONLY WARRANTY, EXPRESS OR IMPLIED, GIVEN BY TTI, I.E., THERE IS NO WARRANTY OF FITNESS FOR A PARTICULAR PURPOSE. TTI HEREBY DISCLAIMS ANY EXPRESS OR IMPLIED WARRANTY OTHER THAN THE WARRANTY IN THE FIRST SENTENCE TO THE FULLEST EXTENT PERMITTED BY LAW.

THE SOLE AND EXCLUSIVE REMEDY UNDER THIS WARRANTY IS REPAIR OR REPLACEMENT AT TTI'S OPTION OF ANY PRODUCT THAT PROVES TO BE DEFECTIVE IN MATERIALS OR MANUFACTURING WITHIN TWO YEARS OF RECEIPT OF THE PRODUCT. NOTE: THIS WARRANTY DOES NOT APPLY TO ANY PRODUCT WHICH HAS BEEN SUBJECT TO MISHANDLING, MISUSE, OR SERVICE BY UNAUTHORIZED PERSONNEL OR TO ANY PRODUCT WHICH HAS BEEN DAMAGED, MODIFIED, ALTERED OR TAMPERED WITH. TO THE FULLEST EXTENT OF THE LAW, TTI DISCLAIMS ALL LIABILITY FOR ANY OTHER DIRECT, INCIDENTAL OR CONSEQUENTIAL DAMAGES ALLEGED TO BE CAUSED BY A DEFECTIVE PRODUCT, I.E., TTI WILL NOT BE RESPONSIBLE FOR ANY PERSONAL INJURY, PROPERTY DAMAGE OTHER THAN THE COST OF REPLACING THE PRODUCT OR ANY OTHER MONETARY DAMAGE SUCH AS LOST WAGES OR PROFITS CAUSED BY ANY USE, ATTEMPTED USE OR INABILITY TO USE THE PRODUCT. NOTE: BY USING THE PRODUCT, YOU AGREE THAT REPAIR OR REPLACEMENT AT TTI'S OPTION WILL FULLY SATISFY TTI'S WARRANTY OBLIGATION TO YOU, WHETHER IN CONTRACT, TORT, NEGLIGENCE, STRICT LIABILITY OR OTHER APPLICABLE LAW.