

LT-880 Laser Tachometer Operating Instructions



Terahertz Technologies Inc.
169 Clear Road Oriskany, New York 13424
(315) 736-3642
Fax: (315) 736-4078
sales@terahertztechnologies.com

March 2004

Table of Contents

PAGE

GENERAL INFORMATION

Introduction.....	2
Specifications.....	3

OPERATING INSTRUCTIONS

Unpacking and Inspection.....	4
Input Power Requirements.....	4
Front Panel.....	5
Safety Considerations	5
Block Diagram.....	6
Operational Considerations.....	7

WARRANTY INFORMATION

Repair Information.....	9
Limited Warranty	9

Introduction

The LT-880 Laser Tachometer is a hand-held, battery operated device that senses the passage of reflective/non-reflective markings on a rotating or linearly translated piece of machinery in order to determine the target's rotational rate or its linear velocity. The sensing head is remote from the electronics package and is fiber coupled. This permits measurement of objects in hostile environments or in hard-to-get-to locations. The sensed change in reflectivity from black to white generates a transition at its output. This TTL/CMOS

compatible signal may be utilized by a spectrum analyzer, computer or electronic counter in order to provide information concerning vibration, angular or linear velocity of the machinery under test. The high speed of the unit, 40 KHz, coupled with its small spot size can provide high resolution measurements unattainable with conventional incandescent source tachometers.



A six digit LCD display indicates the rate of passage of the white/dark areas of the encoder and registers the results in units of revolutions per minute, (RPM), revolutions per second, (RPS), or pulses per second (PPS). The reading is updated twice per second. The user may input the number of pulses per revolution of the encoder for use in the subsequent calculations. They may range from 1 pulse per revolution to 255 pulses per revolution.

The laser wavelength employed by the unit is 650 nm (visible reddish orange). The use of visible light aids the user in targeting the optical system onto the measurement point of interest. It also enables use of a small spot size so that high resolution encoders may be employed.

The LT-880 employs four AA Ni-Mh batteries that power the unit for up to ten hours of continuous operation. It also can operate from a wall-mount type power supply/charger. The charger has a fast charge rate that can charge the batteries to full capacity in about 2 hours.

The optical head is equipped with a five meter length of duplex fiber cable. Other lengths of fiber can be provided up to several hundred meters in length. Right angle attachments are also available.

The use of specially manufactured reflective optical encoders is unnecessary. Encoders may be made with any CAD program and a laser printer on ordinary white copier paper.

Specifications

Units of measurement.....	RPM, RPS, PPS
Display.....	6 digit LCD, 0.375 " hi, 6 LED annunciators
Readout Accuracy.....	0.02% of reading,+/- 1 least significant digit
Measurement update rate.....	twice per second
Range....(using white copier paper).....	12 to 125 mm from exit aperture
Measurement Bandwidth.....	2 Hz - 40 KHz
Laser Wavelength.....	650 +/- 10 nm
Laser Power.....	< 3 mW
Laser Spot Size.....	<1.9 mm @ 13 mm range
Laser Beam Divergence.....	< 13 milliradians
Output Impedance.....	100 Ω
Standard Fiber Optic Cable Length.....	5 m
Standard Fiber Types.....	Receiver - 3 M FT-400-EMT 400 μ M core, Low OH ion content fused silica, Transmitter - 62.5 μ M core fused silica fiber
Fiber Optic Connectors.....	ST Type
Display.....	6 Digit LCD, 6 LED annunciators
Batteries Supplied	4 AA 2000 A-Hr Ni-Mh cells
Charger Power Requirements.....	108-125 VAC, 50-60 Hz, 16 VA Max
Charge Time.....	Approximately 2 hours
Optical Head Dimensions (mm).....	35 L x 13 D
Electronics Package Dimensions (cm).....	200 L x 98 W x 38 D
Total Weight.....	0.46 Kg
Operating Temperature.....	0 - 50 C (Electronics), -40 - 120 C (Optics)

Unpacking and Inspection

Unpacking

The instrument is equipped with the following items: one Optical Head with a five meter fiber optic cable, one Electronics package, operating manual and one power supply /charger. Contact TTI if any item is missing.

Carefully remove each item from its packaging. Take care to keep all optical surfaces such as the ends of the optical fibers free from contamination. Do not remove the dust covers until they are to be used.

INSPECTION

Prior to shipment this instrument was inspected and found to be free of mechanical and electrical defects. Upon acceptance by the carrier he assumes responsibility for its safe arrival. After unpacking, examine the unit for any evidence of shipping damage. Should you receive this instrument in a damaged condition, apparent or concealed, it must be noted on the freight bill or express receipt and signed by the carrier's agent. Failure to do so could result in the carrier refusing to honor the claim. Upon filing a claim Terahertz Technologies Inc. should be notified.

Input Power Requirements

The LT-880 is designed to operate from its internal rechargeable batteries and/or its combination wall-mount supply/charger.

Do not operate the unit with batteries other than 2000 mA-Hr nickel-metal hydride cells that are supplied. Do not operate the unit from the charger without the batteries installed. Do not attempt to use chargers other than the one supplied. Failure to observe these precautions may cause damage to the unit.

The batteries supplied can be recharged hundreds of times. They do not exhibit partial discharge memory effects as do Nickel Cadmium cells.

The North American charger may be operated from 108 - 125 VAC, 50 - 60 Hz. European supplies are equipped with continental European style power connectors and will operate from 210 to 250 VAC, 50 Hz. Total power consumption is approximately 16 W when charging fully depleted cells.

LT-880 Front Panel



Controls

The front panel controls are quite simple. The **Power** switch alternately energizes and de-energizes the unit. The charger will charge the batteries whenever it is plugged into the unit and AC mains regardless of the ON/OFF state of the unit.

The **Units** switch changes the desired units of measurement to RPM, RPS, or PPS.

The **Pulses per Rev** button causes the unit to alternately enter or leave the pulse per revolution set mode. In this mode, the user may use the **Up** and/or **Down** buttons to enter the number of light/dark cycles for the encoder being used. The photo at left shows the pulses per revolution being set to 128. After the desired number is selected, the **Pulses per Rev** should be pressed again and the unit will return to the measurement mode.

The six LED enunciators serve the following functions: **Signal** - Indicates that transitions are being detected by the optical head. **Low Bat** - When on, indicates the batteries are discharged. Approximately 5 more minutes of operation are available after which the unit will automatically shut down. **Fast Charge** - Indicates that the charger is supplying high charging current to the unit. This lights whenever the battery charger is first plugged in. It will automatically revert to trickle charge after a time dependent on the current charge state of the batteries. **RPM, RPS, or PPS** indicate the current units of measurement.

Safety Considerations

This is a laser equipped device and emits sufficient levels of optical radiation to be considered potentially eye damaging. While emitting less power than the average laser pointer, these common sense precautions should be observed.

NEVER look into the beam emitted from the optical head. **DO NOT** point the beam at specularly reflecting (mirror like) surfaces. **NEVER** view the output radiation emitted with optical instruments.

The specific optical characteristics of the emitted beam are as follows:

Beam diam. 2 mm, collimated
Wavelength - 650 +/- 10 nm
Pulse Duration⁵ - Continuous
Output power - less than 3 mW

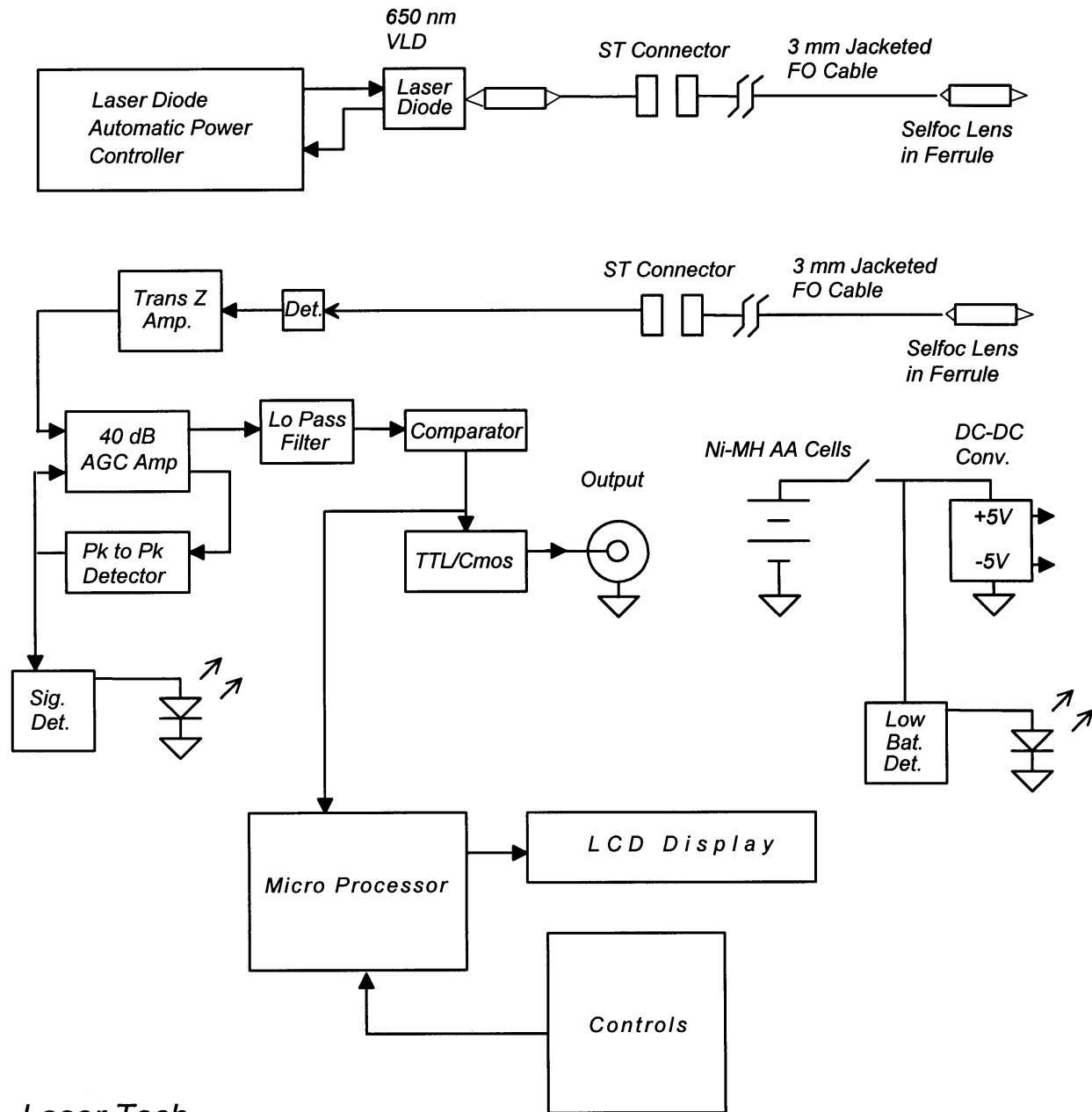

*Laser Tach
Block Diagram*

Fig. 1

Operational Considerations

The LT-880 Laser Tachometer should be operated as follows:

1. Connect the optical head to the electronics package . The small core fiber connects to the Laser output port on the electronics package It is denoted by a reddish rubber ring located behind the connector. There is a similar reddish rubber ring around the laser ST receptacle. The large core fiber connects the Optical Receiver port on the electronics package to the remaining port on the optical head.
2. Position the optical head such that the resting surface of the target to be measured is approximately 13 - 125 mm from the output aperture of the optical head.
3. Depress the **Power** button located on the electronics package.
4. A 2 mm red spot from the laser will appear on the surface of the target. Position as needed.
5. The BNC connector labeled Output will provide a TTL/CMOS compatible logic signal proportional to the rate at which the encoder sectors pass in front of the optical head. The signal is positive (or logic 1) when a reflection is detected.
6. Should the range be in excess of 125 mm or if the target is insufficiently reflective, the **Signal** annunciator will be extinguished.
7. Use the **Units** switch to select the desired units of measurement.
8. Press the **Pulses per Rev** button to verify that the PPr number is correct for the encoder being used. If satisfied, press the button again to return to the measurement mode. To change the setting, use the Up/Down push buttons to select the proper setting.

Ambient Light Levels: Normal fluorescent light levels are acceptable and do not interfere with normal operation. Bright light on the target or directed at the optical head should be avoided.

Optical Surfaces: Always keep the fiber optic connectors clean. Keep them in the connectors or the caps supplied. The fiber connectors and the small lenses at the end of the optical head may be cleaned with isopropyl alcohol and a clean optical tissue or Kimwipe. Fiber optic cleaning swabs may be used if it is suspected that the internal fiber optic connectors have become contaminated.

Fiber Optic Cable: ***Do not sharply bend or kink the fiber optic cable. Bend radius should be kept to a minimum of four inches.***

Encoder Characteristics: - The LT-880 has been designed to operate without dependence on special reflective tape or encoders. A encoder may be generated with almost any CAD drawing program such as AutoCad, Fast Cad, or CadKey. The drawing should be printed on a laser printer on white paper. The number of spokes is determined by the number of pulses per revolution that is required (more pulses per revolution are generally better in that higher order harmonics may be detected without sampling aliasing). The main consideration is that the white spaces between the spokes be wide enough accommodate the laser beam at the target distance being used. An example of a typical target is shown below.

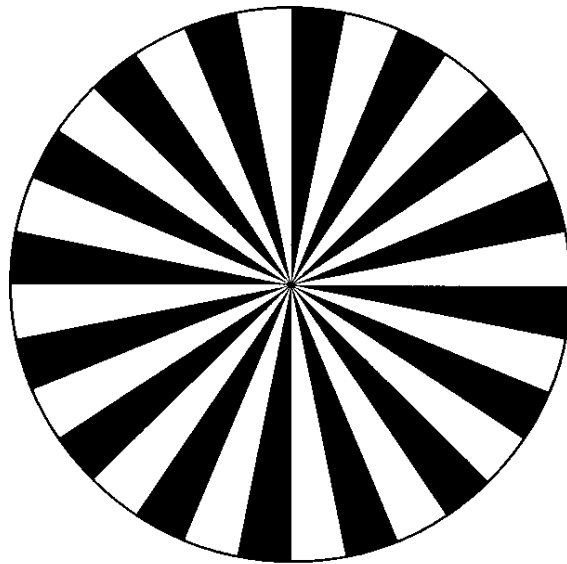

16 PPr Encoder

Orientation of beam to surface - The beam should always be at an angle to the plane of the encoder. If the beam is perpendicular to the surface, specular reflections will be introduced which will reduce the contrast of the light to dark areas and may cause unstable measurements.

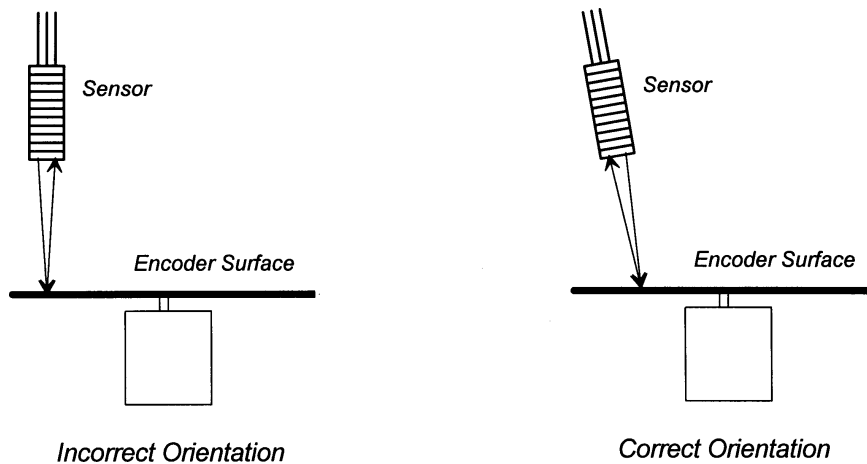

Warranty And Repair Information

REPAIR INFORMATION

Products manufactured by Terahertz Technologies Inc. are designed and manufactured to provide reliable performance. However, in the event that service is required, both telephone technical assistance and factory repair services are available. Call (315) 736-3642, FAX 736-4078 or E-mail (tti@borg.com) for information.

For IN-WARRANTY REPAIRS, call us to obtain a Returned Material Authorization number, (RMA Number). All products are to be returned to TTI with freight charges pre-paid. Those products sent under warranty will be returned to our customers pre-paid. We cannot be responsible for returned products that do not reference the TTI RMA number.

For OUT-OF-WARRANTY repairs, services are billable for both time and materials.

LIMITED WARRANTY

TERAHERTZ TECHNOLOGIES INC. ("TTI") WARRANTS THAT TO THE FIRST PURCHASER, FOR A PERIOD OF TWO YEARS FROM THE DATE OF RECEIPT, THAT THIS PRODUCT ("THE PRODUCT") WILL BE FREE FROM DEFECTS IN MATERIALS AND MANUFACTURING. THE FOREGOING WARRANTY IS THE ONLY WARRANTY, EXPRESS OR IMPLIED, GIVEN BY TTI, I.E., THERE IS NO WARRANTY OF FITNESS FOR A PARTICULAR PURPOSE. TTI HEREBY DISCLAIMS ANY EXPRESS OR IMPLIED WARRANTY OTHER THAN THE WARRANTY IN THE FIRST SENTENCE TO THE FULLEST EXTENT PERMITTED BY LAW. THE SOLE AND EXCLUSIVE REMEDY UNDER THIS WARRANTY IS REPAIR OR REPLACEMENT AT TTI'S OPTION OF ANY PRODUCT THAT PROVES TO BE DEFECTIVE IN MATERIALS OR MANUFACTURING WITHIN TWO YEARS OF RECEIPT OF THE PRODUCT. NOTE: THIS WARRANTY DOES NOT APPLY TO ANY PRODUCT WHICH HAS BEEN SUBJECT TO MISHANDLING, MISUSE, OR SERVICE BY UNAUTHORIZED PERSONNEL OR TO ANY PRODUCT WHICH HAS BEEN DAMAGED, MODIFIED, ALTERED OR TAMPERED WITH. TO THE FULLEST EXTENT OF THE LAW, TTI DISCLAIMS ALL LIABILITY FOR ANY OTHER DIRECT, INCIDENTAL OR CONSEQUENTIAL DAMAGES ALLEGED TO BE CAUSED BY A DEFECTIVE PRODUCT, I.E., TTI WILL NOT BE RESPONSIBLE FOR ANY PERSONAL INJURY, PROPERTY DAMAGE OTHER THAN THE COST OF REPLACING THE PRODUCT OR ANY OTHER MONETARY DAMAGE SUCH AS LOST WAGES OR PROFITS CAUSED BY ANY USE, ATTEMPTED USE OR INABILITY TO USE THE PRODUCT. NOTE: BY USING THE PRODUCT, YOU AGREE THAT REPAIR OR REPLACEMENT AT TTI'S OPTION WILL FULLY SATISFY TTI'S WARRANTY OBLIGATION TO YOU, WHETHER IN CONTRACT, TORT, NEGLIGENCE, STRICT LIABILITY OR OTHER APPLICABLE LAW.