

Optical to Electrical Converter

Features:

- Large Area InGaAs detector
- DC to 14GHz Bandwidth
- 900-1700nm
- Universal Power Supply
- Capability to drive 50 Ohm output loads



Applications:

- General laboratory testing of optical components
- Field Service Testing and Troubleshooting
- Laser alignment and tuning
- Plasma physics measurements



The TIA-1200 Optical to Electrical Converter is a wide-band detection system for fiber optic applications. With a typical bandwidth of DC to 14 GHz (min 12 GHz), it accurately provides an electrical replica of the optical signal presented to it. It is intended to drive a 50 ohm cable terminated in its characteristic impedance.

The unit is equipped with an InGaAs/InP detector that is responsive in the wavelength range of 900 - 1700 nm. The TIA-1200 is provided with an FC or FC/APC fiber optic receptacle. The output signal is presented to a type K SMA female connector.

The TIA-1200 detector is 50 microns in diameter. Optionally, it may be ordered with a 50 micron fiber, thus allowing both single mode and multimode sources to be tested without incurring excessive coupling losses.

Typical optical return loss is 35 dB and is caused primarily by the FC/PC connector employed. If higher return loss is needed, The unit may be optionally equipped with single mode angled PC connectors for ORLs of around 52 dB.



Made In the USA

Terahertz Technologies Inc.
169 Clear Rd, Oriskany NY 13424
Phone: 315-736-3642 Fax: 315-736-4078
email: sales@terahertztechnologies.com
web: www.terahertztechnologies.com

TIA-1200 Specifications

Detector Type	InGaAs/InP (900-1700nm)
Current Responsivity	0.8 A/W @ 1550nm Typical
Maximum Linear Input Power	3mw
Maximum Input Power without Damage	10mw
Bandwith-(3dB)	DC to 14GHz Typical, 12 GHz Minimum
Output Impedance	50 Ohms
Output Connector	Type K SMA Female
Fiber Optic Input Connector	FC or FC/APC
Input Numerical Aperture	0.11
Optical Return Loss	>35dB, >52dB with APC Connection
Power	Universal Power Supply
Dimensions	1.2"W x 2.5"L x 1.3"H (30.5mm x 63mm x 33mm)
Weight	5.6oz (0.16 Kg)
LED Annunciators Provided	Power On
Operating Temperature Range	0 - 40 C
Standard Warranty	Two Years, Component and Workmanship, 30 Day Satisfaction Guarantee
Accessories Supplied	Transit/Storage Case, Operating Manual, Universal Power Supply

TTI reserves the right to change specifications without notice.

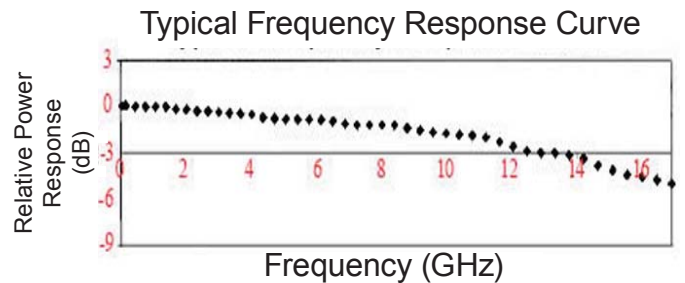
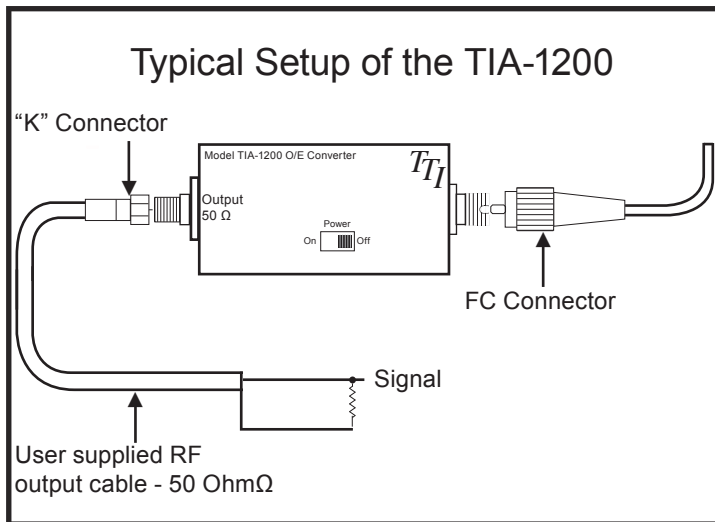

We welcome the challenge of custom applications.

Call, Fax or e-mail us with your requirements.



Terahertz Technologies Inc.
 169 Clear Rd, Oriskany NY 13424
 Phone: 315-736-3642 Fax: 315-736-4078
 email: sales@terahertztechnologies.com
 web: www.terahertztechnologies.com

Made In the USA

